

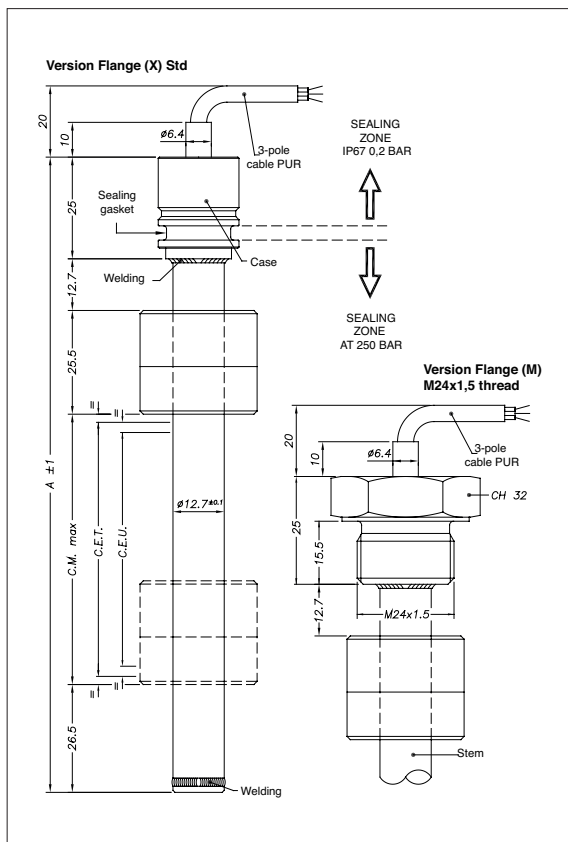

Applicative characteristics

- The PMI-SL transducer, an evolution of the PMI-12, is designed for all inside cylinder applications which require a smaller transducer.
For this reason, the diameter has been reduced to 12.7 mm.
- The PMI Slim offers the same robustness as the PMI-12: AISI 316 stainless steel body, IP67 protection level, and pressure resistance up to 250 bar (400 bar peak)
- Available with flanged or threaded heads, to guarantee mechanical compatibility with all main cylinder types
- Patented solution
- Ideal for applications inside hydraulic cylinders, demanding simple solutions which guarantee measurement repeatability.

MECHANICAL DIMENSION



Important: all the data reported in the catalogue linearity and temperature coefficients are valid for sensor utilization as a ratiometric device with a max current across the cursor $I_c \leq 0.1 \mu A$.

TECHNICAL DATA

Useful electrical stroke (C.E.U.)

50/100/150/200/250/300/350/400/450/500/550/600/750/800/850/900/950/1000

Independent linearity (within C.E.U.)

$\pm 0,35\%$

Resolution

Infinite

Repeatability

≤ 0.08 mm

Hysteresis

$< 250 \mu m$

Life

$> 25 \times 10^6$ m strokes, or $> 100 \times 10^6$ maneuvers, whichever is less

Electrical connection

1 mt 3-pole shielded cable

Displacement speed

standard ≤ 5 m/s

Max. acceleration

$\leq 10 m/s^2$ max displacement

Cursor dragging force

≤ 0.5 N

Vibrations

5...2000Hz, $A_{max} = 0,75$ mm $a_{max} = 20$ g

Shock

50 g, 11 ms.

Displacement sensitivity (no hysteresis)

from 0.05 to 0.1 mm

Tracking error

see table

Tolerance on resistance

$\pm 20\%$

Recommended cursor current

$< 0,1 \mu A$

Maximum cursor current in case of bad performances

10mA

Maximum applicable voltage

see table

Electrical isolation

$> 100 M\Omega$ at 500V~, 1bar, 2s

Dielectric strenght

$< 100 \mu A$ at 500V~, 50Hz, 2s, 1bar

Dissipation at 40°C (0W at 120°C)

see table

Thermal coefficient of resistance

-200...+200 ppm/°C typical

Actual Temperature coefficient of the output voltage

≤ 5 ppm/°C typical

Working temperature

-30...+100°C

Storage temperature

-50...+120°C

Material for transducer case

AISI 304

MECHANICAL / ELECTRICAL DATA

MODEL		50	100	150	200	250	300	350	400	450	500	550	600	750	800	850	900	950	1000	
Useful electrical stroke (C.E.U.) + 1/-0	mm	Model																		
Theoretical electrical stroke (C.E.T.) ± 1	mm	C.E.U. + 1																		
Independent linearity (within C.E.U.)	± %	0.35																		
Dissipation at 40°C (0W at 120°C)	W	1	2																	3
Max applicable voltage	V	40																	60	
Resistance (C.E.T.)	kΩ	5					10					20								
Mechanical stroke (C.M.)	mm	C.E.U. + 5																		
Case Length "A" ± 1	mm	C.E.U. + 94.7																		

PCUR010 CURSOR

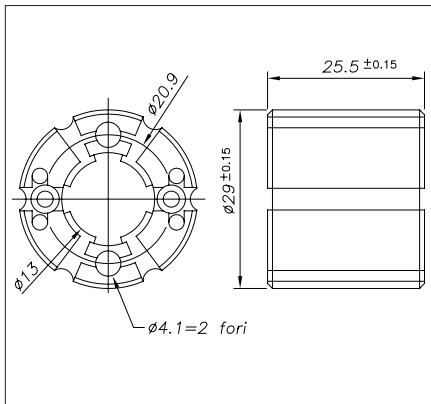

STANDARD FLANGE (X)

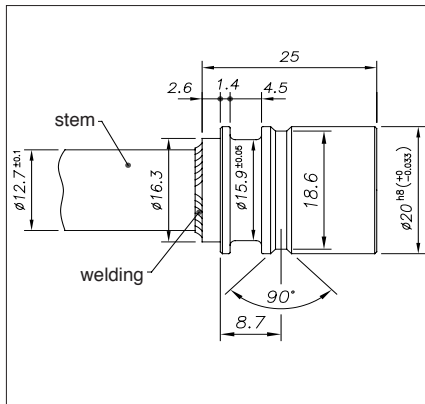

THREADED FLANGE (M)

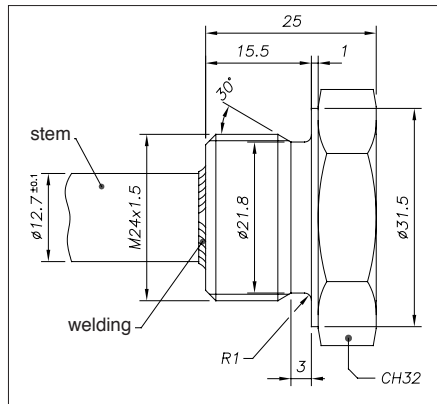

INSTALLATION INSIDE THE CYLINDER

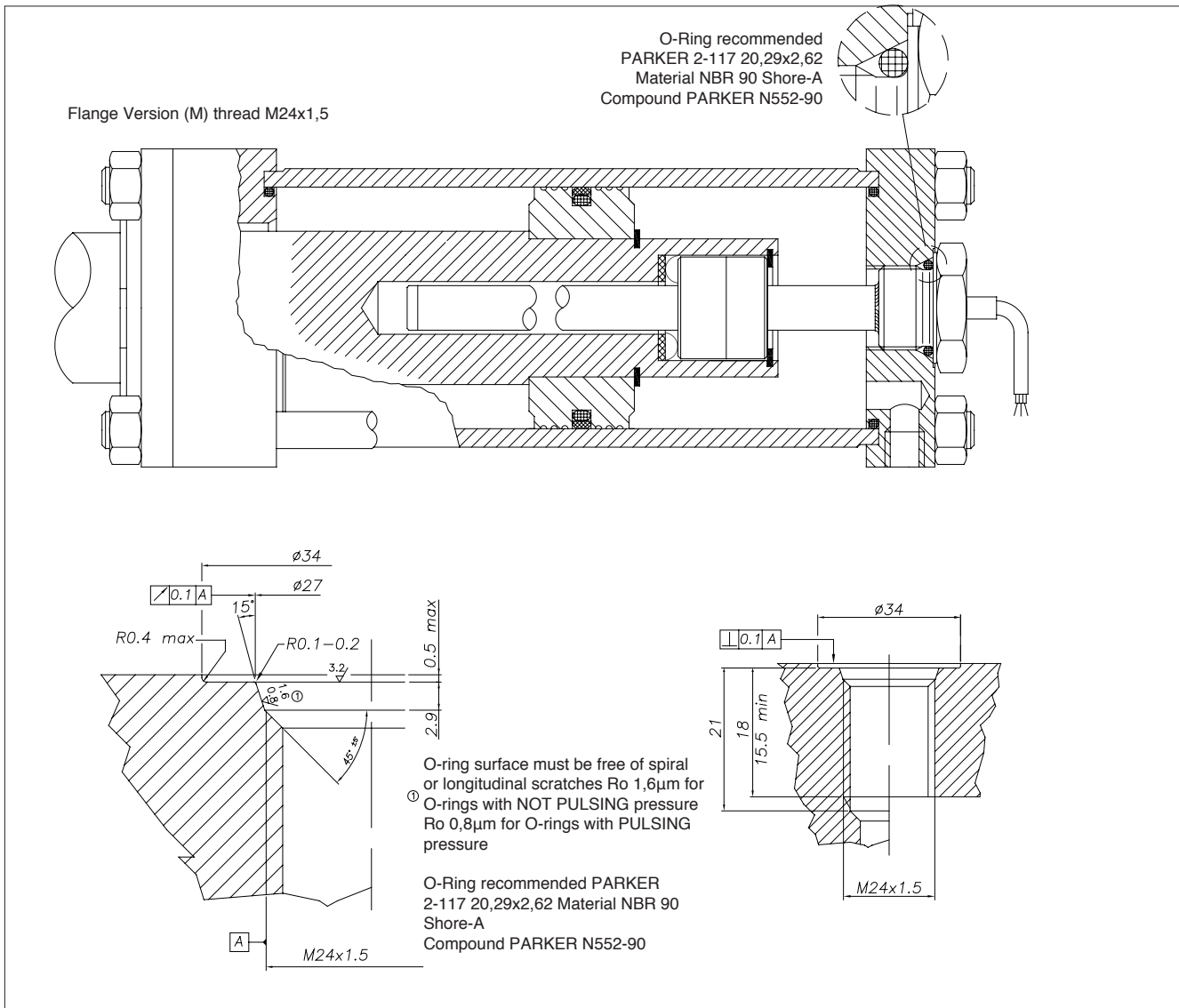

INSTALLATION INSIDE THE CYLINDER

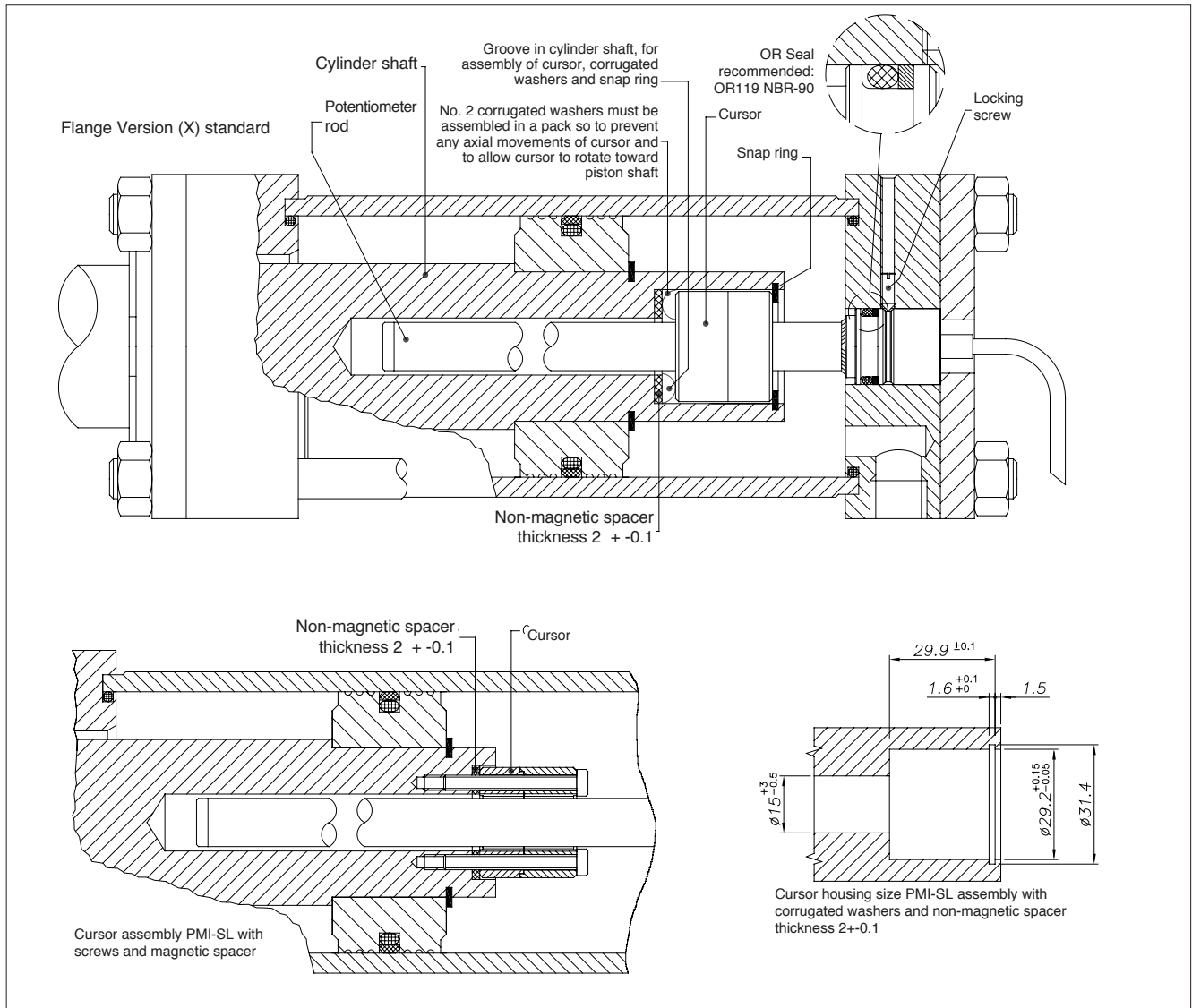

ELECTRICAL CONNECTIONS

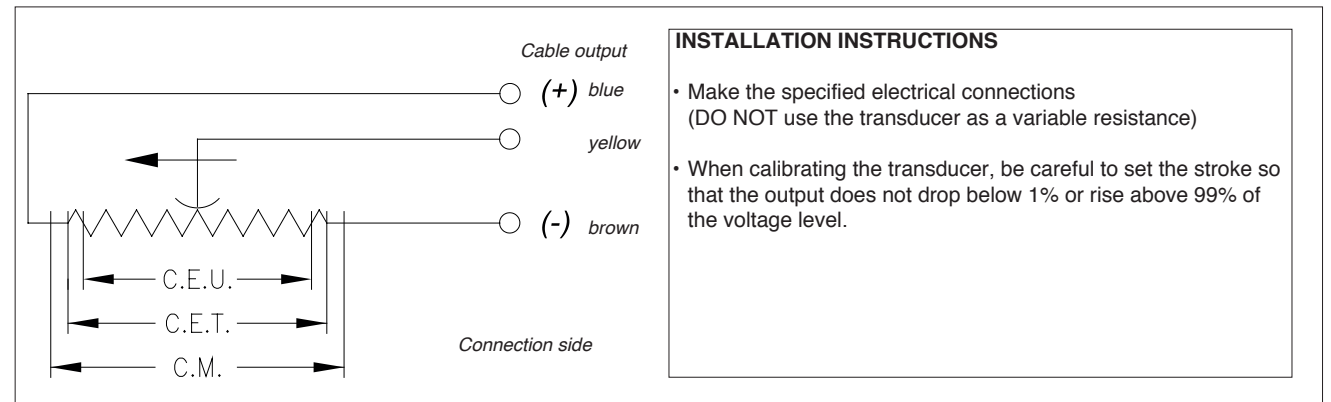

TRACKING ERROR

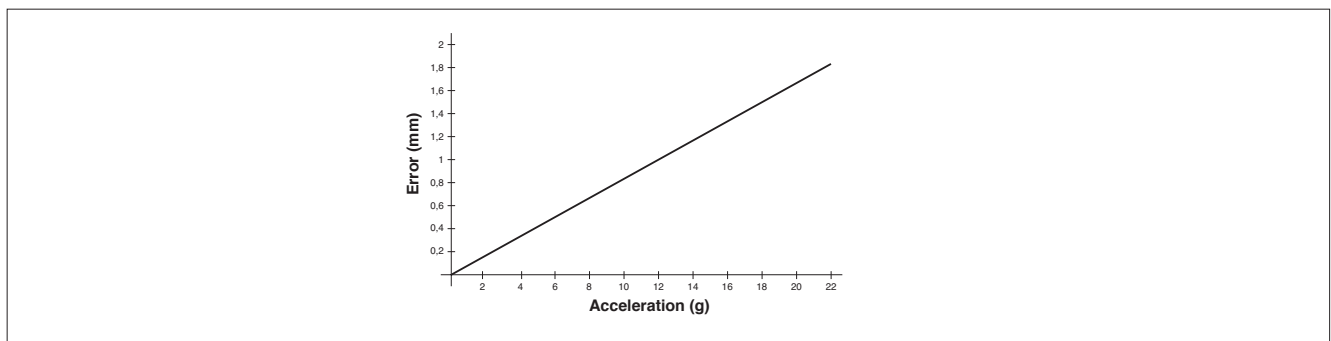

ORDER CODE

Displacement transducers P M I S L

3-pole PUR cable output 3x0.25, 1 mt	F
Model	
Standard flange	X
Threaded flange M24x1.5	M

No certificate attached	0
Linearity curve to be attached	L

Version F cable length	
1 mt cable (standard)	00
2 mt cable	02
3 mt cable	03
4 mt cable	04
5 mt cable	05
10 mt cable	10
15 mt cable	15

Ex.: **PMI-SL-F-0400-X 0000X000XX00XXX**
 PMI SL displacement transducer, cable output, useful electrical stroke (C.E.U.)
 400mm, standard flange, no certificate attached, cable length 1 mt.

ACCESSORIES (standard)

Standard magnetic cursor

PCUR010

GEFRAN spa reserves the right to make any kind of design or functional modification at any moment without prior notice